

# S-64E TECHNICAL AND PERFORMANCE INFORMATION

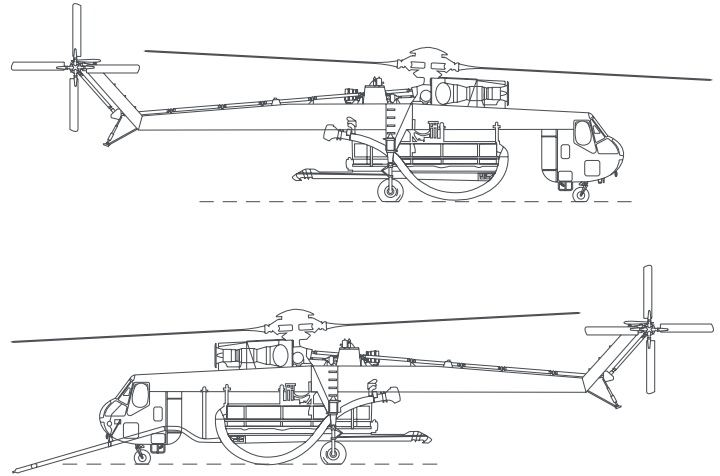
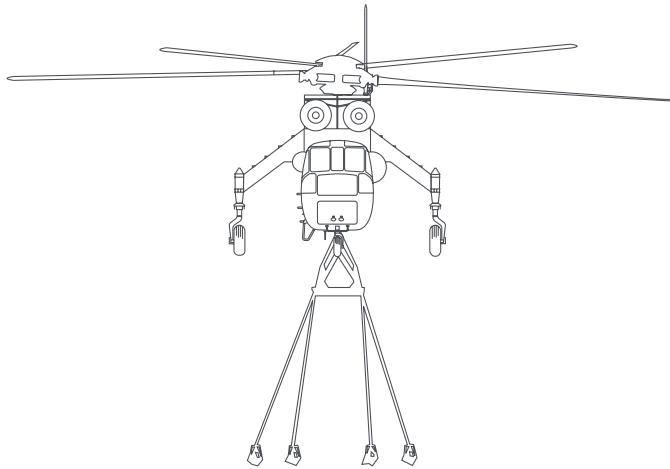

## POWER PLANT (2 ERICKSON JFTD12A-4A)

Maximum Power Available	9,000 SHP
Single Engine Limit	4,500 SHP / 30 min.
	<i>*Gearbox limit is 4,050</i>

## GENERAL

Maximum Gross Weight	42,000 lbs (19,050 kg)
Maximum Hook Weight	20,000 lbs (9,072 kg)
Maximum Cruise Speed	115 kts (212 km/hr)
Maximum Range	238 nm (20 minute reserve) 258 nm (no reserve)

## FUSELAGE (NON-PRESSURIZED)

Length*	69 ft 8 in (21.20 m)
Width*	7 ft 1 in (2.13 m)
Width Landing Gear	21 ft 10.70 in (6.67 m)

*\*Fuselage only, External Dimensions*

## MAIN ROTOR

Main Rotor Diameter	72 ft 2.85 in (22.7 m)
Disc Area	4,072 sq. ft (378.3 sq. m)

## TAIL ROTOR

Tail Rotor Dimension	16 ft (4.90 m)
Disc Area	201.1 sq. ft (18.7 sq. m)

## LANDING GEAR

Main Gear	Wheeled
Nose Gear	Wheeled
Wheel Base	24 ft 4.32 in (7.43 m)

## AIRCRAFT EQUIPMENT – CONFIGURATION ITEMS

### AVIONICS

- Glass Cockpit (optional)
- Global Positioning Satellite (GPS)
- Automated Flight Tracking System (with mission-specific data)
- Satellite Phone capable
- Emergency Locator Transmitter (406MHz - 5 Axis)
- VHF Radio Packages (Dual)
- VHF FM Radio Packages (Dual)
- ADS-B System (In & Out)
- SATCOM Antenna
- Radar Altimeter
- Flight Data Monitoring System (FDMS)
- Max-Viz (Enhanced Vision system)

### MISSION-SPECIFIC EQUIPMENT

- Fire Tank
- Sea Snorkel
- Pond Snorkel
- Foam Cannon
- Hoist
- Anti-Rotation Device
- Shock and Pendant
- Grapple
- NVG Cockpit (optional)
- Hydro-seed
- Cargo Pod (Fly Away Box)